

Sleeve-All® Design Information — Concrete and Masonry



Allowable Tension and Shear Loads for Sleeve-All® in Normal-Weight Concrete

Size in. (mm)	Embed. Depth in. (mm)	Critical Edge Dist. in. (mm)	Critical Spacing Dist. in. (mm)	Tension Load						Shear Load			Install. Torque ft.-lb. (N-m)
				$f'_c \geq 2,000$ psi (13.8 MPa) Concrete			$f'_c \geq 4,000$ psi (27.6 MPa) Concrete			$f'_c \geq 2,000$ psi (13.8 MPa) Concrete			
				Ultimate lb. (kN)	Std. Dev. lb. (kN)	Allow. lb. (kN)	Ultimate lb. (kN)	Std. Dev. lb. (kN)	Allow. lb. (kN)	Ultimate lb. (kN)	Std. Dev. lb. (kN)	Allow. lb. (kN)	
¼ (6.4)	1½ (29)	2½ (64)	4½ (114)	880 (3.9)	94 (0.4)	220 (1.0)	1,320 (5.9)	189 (0.8)	330 (1.5)	1,440 (6.4)	90 (0.4)	360 (1.6)	5 (7)
⅝ (7.9)	1⅞ (37)	3⅞ (79)	5¾ (146)	1,120 (5.0)	113 (0.5)	280 (1.2)	1,320 (5.9)	350 (1.6)	330 (1.5)	2,160 (9.6)	113 (0.5)	540 (2.4)	8 (11)
¾ (9.5)	1½ (38)	3¾ (95)	6 (152)	1,600 (7.1)	294 (1.3)	400 (1.8)	2,680 (11.9)	450 (2.0)	670 (3.0)	3,080 (13.7)	223 (1.0)	770 (3.4)	15 (20)
½ (12.7)	2¼ (57)	5 (127)	9 (229)	3,160 (14.1)	254 (1.1)	790 (3.5)	4,760 (21.2)	485 (2.2)	1,190 (5.3)	5,000 (22.2)	473 (2.1)	1,250 (5.6)	25 (34)
⅝ (15.9)	2¾ (70)	6¼ (159)	11 (279)	4,200 (18.7)	681 (3.0)	1,050 (4.7)	6,160 (27.4)	1,772 (7.9)	1,540 (6.9)	8,520 (37.9)	713 (3.2)	2,130 (9.5)	50 (68)
¾ (19.1)	3¾ (86)	7½ (191)	13½ (343)	6,400 (28.5)	665 (3.0)	1,600 (7.1)	9,520 (42.3)	674 (3.0)	2,380 (10.6)	10,040 (44.7)	955 (4.2)	2,510 (11.2)	90 (122)

- The tabulated allowable loads are based on a safety factor of 4.0.
- Allowable loads may not be increased for short-term loading due to wind or seismic forces.
- Refer to allowable load-adjustment factors for spacing and edge distance on page 183.
- Drill bit diameter used in base material corresponds to nominal anchor diameter.
- Allowable tension loads may be linearly interpolated between concrete strengths listed.
- The minimum concrete thickness is 1 ½ times the embedment depth.

Allowable Tension and Shear Loads for ⅜" Sleeve-All® in Grout-Filled CMU (Anchor Installed in Horizontal Mortar Joint or Face Shell)

Size in. (mm)	Embed. Depth in. (mm)	Min. Edge Dist. in. (mm)	Min. End Dist. in. (mm)	Min. Spacing in. (mm)	Tension Load		Shear Load		Install. Torque ft.-lb. (N-m)
					Ultimate lb. (kN)	Allow. lb. (kN)	Ultimate lb. (kN)	Allow. lb. (kN)	
⅜ (9.5)	1½ (38)	16 (406)	16 (406)	24 (610)	2,000 (8.9)	400 (1.8)	2,300 (10.2)	460 (2.0)	15 (20)

See notes beneath following table.

Allowable Tension and Shear Loads for Sleeve-All® in Grout-Filled CMU

Size in. (mm)	Embed. Depth in. (mm)	Min. Edge Dist. in. (mm)	Min. End Dist. in. (mm)	Min. Spacing in. (mm)	Tension Load		Shear Load		Install. Torque ft.-lb. (N-m)
					Ultimate lb. (kN)	Allow. lb. (kN)	Ultimate lb. (kN)	Allow. lb. (kN)	
Anchor Installed in a Single Face Shell									
⅜ (9.5)	1½ (38)	12 (305)	12 (305)	24 (610)	1,746 (7.8)	350 (1.6)	2,871 (12.8)	575 (2.6)	15 (20)
½ (12.7)	2¼ (57)	12 (305)	12 (305)	24 (610)	3,384 (15.1)	675 (3.0)	5,670 (25.2)	1,135 (5.0)	25 (34)
⅝ (15.9)	2¾ (70)	12 (305)	12 (305)	24 (610)	3,970 (17.7)	795 (3.5)	8,171 (36.3)	1,635 (7.3)	50 (68)
¾ (19.1)	3¾ (86)	12 (305)	12 (305)	24 (610)	6,395 (28.4)	1,280 (5.7)	12,386 (55.1)	2,475 (11.0)	90 (122)
Anchor Installed in Mortar "T" Joint									
⅜ (9.5)	1½ (38)	8 (203)	8 (203)	24 (610)	1,927 (8.6)	385 (1.7)	3,436 (15.3)	685 (3.0)	15 (20)
½ (12.7)	2¼ (57)	8 (203)	8 (203)	24 (610)	3,849 (17.1)	770 (3.4)	5,856 (26.0)	1,170 (5.2)	25 (34)
⅝ (15.9)	2¾ (70)	8 (203)	8 (203)	24 (610)	4,625 (20.6)	925 (4.1)	7,040 (31.3)	1,410 (6.3)	50 (68)
¾ (19.1)	3¾ (86)	8 (203)	8 (203)	24 (610)	5,483 (24.4)	1,095 (4.9)	7,869 (35.0)	1,575 (7.0)	90 (122)

- The tabulated allowable loads are based on a safety factor of 5.0.
- Listed loads may be applied to installations through a face shell with the following placement guidelines:
 - Minimum 3" from vertical mortar joint.
 - Minimum 1" from vertical cell centerline.
- Values for 6- and 8-inch-wide concrete masonry units (CMU) with a minimum specified compressive strength of masonry, f'_m , at 28 days is 1,500 psi.
- Embedment depth is measured from the outside face of the concrete masonry unit.
- Drill bit diameter used in base material corresponds to nominal anchor diameter.

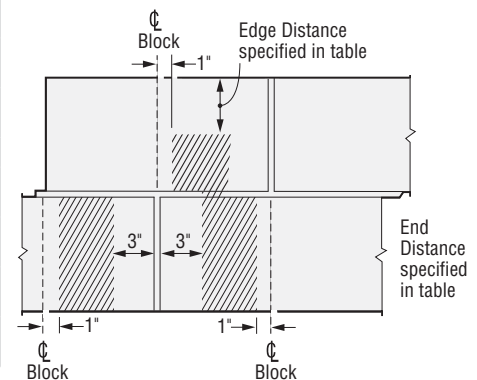

Face Shell Installation
Allowable Anchor Placement in grout-filled CMU shown by shaded areas.

* See page 12 for an explanation of the load table icons.

Sleeve-All® Design Information — Concrete

Allowable Load-Adjustment Factors for Sleeve-All® Anchors in Normal-Weight Concrete:
Edge Distance and Spacing, Tension and Shear Loads

How to use these charts:

1. The following tables are for reduced edge distance and spacing.
2. Locate the anchor size to be used for either a tension and/or shear load application.
3. Locate the edge distance (c_{act}) or spacing (s_{act}) at which the anchor is to be installed.
4. The load adjustment factor (f_c or f_s) is the intersection of the row and column.
5. Multiply the allowable load by the applicable load adjustment factor.
6. Reduction factors for multiple edges or spacing are multiplied together.

Edge Distance Tension (f_c)

Edge Dist. C _{act} (in.)	Size	¼	⅝	¾	½	⅝	¾
	c_{cr}	2½	3⅜	3¾	5	6¼	7½
c_{min}	1¼	1⅞	1⅞	2½	3⅜	3¾	
f_{cmin}	0.60	0.60	0.60	0.60	0.60	0.60	0.60
1¼		0.60					
1½		0.68					
1⅞		0.70	0.60				
1⅞		0.80	0.68	0.60			
2		0.84	0.71	0.63			
2½		1.00	0.84	0.73	0.60		
3			0.97	0.84	0.68		
3⅜			1.00	0.87	0.70	0.60	
3½				0.95	0.76	0.65	
3¾				1.00	0.80	0.68	0.60
4					0.84	0.71	0.63
4½					0.92	0.78	0.68
5					1.00	0.84	0.73
5½						0.90	0.79
6						0.97	0.84
6¼						1.00	0.87
6½							0.89
7							0.95
7½							1.00

See notes below.

Edge Distance Shear (f_c)

Edge Dist. C _{act} (in.)	Size	¼	⅝	¾	½	⅝	¾
	c_{cr}	2½	3⅜	3¾	5	6¼	7½
c_{min}	1¼	1⅞	1⅞	2½	3⅜	3¾	
f_{cmin}	0.30	0.30	0.30	0.30	0.30	0.30	0.30
1¼		0.30					
1½		0.44					
1⅞		0.48	0.30				
1⅞		0.65	0.44	0.30			
2		0.72	0.50	0.35			
2½		1.00	0.72	0.53	0.30		
3			0.94	0.72	0.44		
3⅜			1.00	0.77	0.48	0.30	
3½				0.91	0.58	0.38	
3¾				1.00	0.65	0.44	0.30
4					0.72	0.50	0.35
4½					0.86	0.61	0.44
5					1.00	0.72	0.53
5½						0.83	0.63
6						0.94	0.72
6¼						1.00	0.77
6½							0.81
7							0.91
7½							1.00

1. c_{act} = actual edge distance at which anchor is installed (inches).
2. c_{cr} = critical edge distance for 100% load (inches).
3. c_{min} = minimum edge distance for reduced load (inches).
4. f_c = adjustment factor for allowable load at actual edge distance.
5. f_{ccr} = adjustment factor for allowable load at critical edge distance.
 f_{ccr} is always = 1.00.
6. f_{cmin} = adjustment factor for allowable load at minimum edge distance.
7. $f_c = f_{cmin} + [(1 - f_{cmin}) (c_{act} - c_{min}) / (c_{cr} - c_{min})]$.

* See page 12 for an explanation of the load table icons.

Spacing Tension and Shear (f_s)

S _{act} (in.)	Size	¼	⅝	¾	½	⅝	¾
	E	1⅞	1⅞	1½	2¼	2¼	3⅞
s_{cr}	4½	5¾	6	9	11	13½	
s_{min}	2¼	2⅞	3	4½	5½	6¾	
f_{smin}	0.50	0.50	0.50	0.50	0.50	0.50	0.50
2¼		0.50					
2½		0.56					
2⅞		0.64	0.50				
3		0.67	0.52	0.50			
3½		0.78	0.61	0.58			
4		0.89	0.70	0.67			
4½		1.00	0.78	0.75	0.50		
5			0.87	0.83	0.56		
5½			0.96	0.92	0.61	0.50	
5¾			1.00	0.96	0.64	0.52	
6				1.00	0.67	0.55	
6½					0.72	0.59	
6¾					0.75	0.61	0.50
7					0.78	0.64	0.52
8					0.89	0.73	0.59
9					1.00	0.82	0.67
10						0.91	0.74
11						1.00	0.81
12							0.89
13							0.96
13½							1.00

1. E = Embedment depth (inches).
2. s_{act} = actual spacing distance at which anchors are installed (inches).
3. s_{cr} = critical spacing distance for 100% load (inches).
4. s_{min} = minimum spacing distance for reduced load (inches).
5. f_s = adjustment factor for allowable load at actual spacing distance.
6. f_{scr} = adjustment factor for allowable load at critical spacing distance.
 f_{scr} is always = 1.00.
7. f_{smin} = adjustment factor for allowable load at minimum spacing distance.
8. $f_s = f_{smin} + [(1 - f_{smin}) (s_{act} - s_{min}) / (s_{cr} - s_{min})]$.